

Optimization of concrete sleepers subjected to static and impact loadings

Ndabamenye Theogene¹, Ntakiyemungu Mathieu^{1*} and Abrham Gebre¹

¹African Railway Center of Excellence, Addis Ababa Institute of Technology, Addis Ababa University, Ethiopia

ABSTRACT

Prestressed concrete sleepers play an essential role in the railway track's performance and safety responses, having an important function of transferring and distributing loads from the track's superstructure to ballast bed. Cracks on the prestressed concrete sleepers are mainly caused by impact loadings from wheel and rail interactions. Thus, the excessive railway track maintenance cost. The effect and optimization of different prestressed sleeper shape under static and impact loadings has not been previously well investigated. Therefore, this paper focused on the optimization of prestressed concrete sleepers (PCS) shape looking at sleeper safety and sleeper volume. ANSYS 16 was used to analyze the static and impact loading on sleepers. The concrete part of the sleeper was modelled using a three-dimensional solid element, SOLID65 and the pre-stressing wires by truss elements, LINK180, to withstand the initial strain attributed to pre-stressing forces. This paper revealed that irregular hexagon sleeper shape with different width at rail seat and center section having 251 mm and 175 mm center width and height respectively; 281 mm and 200 mm end and rail seat width and height respectively is safe. This paper; thus, point out to irregular hexagonal shape sleeper are more economical and safe unlike the other modelled shapes.

Keywords: Prestressed concrete sleeper; static and impact loadings; ANSYS, Finite element; optimization

History

Received: 04.07.2021

Accepted: 21.08.2021

Author Contacts

*Corresponding Author

e-mail addresses : ntakmatnty@gmail.com, ninitha2020@yahoo.com,
abrhamgebre16@gmail.com

Orcid numbers : 0000-0003-4862-8940, 0000-0001-9872-9040, 0000-0003-0172-2905

<http://dx.doi.org/10.29228/eng.pers.52117>

1. Introduction

Sleepers form an integral part of the railway superstructure track components that help in transmission of rail vertical loads to the substructure. As reported by [1], the most important functions of railway sleeper include the transfer and distribution of vertical loads from superstructure to foundation, restrain of lateral, longitudinal and vertical movement of rails. Cracks in concrete sleepers are due to impact loading caused by wheel/rail interaction with or without wheel/rail irregularities. [2, 3 &4], noted that impact loads appear in short duration but of very high magnitude wheel loads due to abnormalities on the wheels and or on the railhead surface. Prestressed concrete sleeper (PCS) was analyzed numerically and analytically by different researchers. The analytical and numerical method was conducted by [5], to analyse and optimize a PCS by varying one shape dimensions of the existing sleeper. Concrete grade, and tendon (wire) type and profile were considered. Moreover, [5] did not consider impact loading in the design and other sleeper shapes like rectangular, hexagonal sleeper sections. Prestressed concrete sleeper

was optimized by [6] considering different dimensions and pressure distribution beneath the sleeper. In the analysis, only one cross section shape has been used, others cross section shape at both rail seat and center of sleeper were overlooked. Optimization of prestressed concrete sleeper has been conducted by [7] using sensitivity analysis with different sleepers so as to determine the number and position of rebars. Studies on different sleeper shapes and dimensions were overlooked. The effect and optimization of different prestressed concrete sleeper shape subjected to both static and impact loading were not previously well investigated. PC design has utilized the permissible stress principle taking into account only the static and quasi-static loads used in the design of PC sleepers, thus not tolerating the small sleeper cracks due to large spikes from track loading. Cracked sleepers must be replaced by new sleeper, that make the railway maintenance very costly. The main objective of this study is to numerically investigate the behaviour of concrete sleeper and optimize sleeper shape subjected to static and impact loadings.

2. Optimization formulation

Optimization is defined as the selection of the best element which can be cost, profit, quality, safety or environment impact; from some set of available alternatives. In this paper, optimization was conducted to ensure the sleeper safety and volume. In this case, two objective functions are analyzed. As reported by [8]; to transform a multiobjective optimization problem into a single objective; weighted sum method could be used. Objective functions such as sleeper safety and sleeper cost in times of sleeper total volume are given as $f_1(x)$ and $f_2(x)$ respectively. Combining the two, the following scalar objective is given as:

$$F(x) = \alpha_1 f_1(x) + \alpha_2 f_2(x) \quad (1)$$

Where, α_1 and α_2 are the weighting coefficients with $\alpha_1 + \alpha_2 = 1$, α_1 and α_2 are from literatures. According to [9], in his study; a rail safety of 59% was reported with 41 % cost. The sleeper safety is based on the way the sleepers behave under both static and impact loading. Bending stress at top and bottom has to be considered and compared to the permissible stress provided by AS 1085.14 [10]. The sleeper volume was also taken into account. The weighted sum method was used to select the best geometrical sleeper shape. The two objective functions (safety and volume) are formulated from ANSYS software after importing some parameter into the software.

3. Model Validation

Static sleeper model was modelled, analyzed and compared with Rikard (2000) model [11]. ANSYS 16 was used to simulate the behaviours of a sleeper. Three-dimensional solid element, SOLID 65 was used to model concrete part which has the material model to predict the failure of brittle materials. To simulate the behaviour of prestressing wires, truss elements, LINK180, were used to withstand the initial strain attributed to prestressing forces, by assuming perfect bond between these elements and concrete. Sleeper was subjected to the same hydraulic jack loading as Rikard model (2000). The load is applied to the rail seat area varying from 0 to 237.5 kN. The vertical deformation as shown in figure 1 at a load of 237.5 kN shows symmetry of the sleeper at the centre and it shows the maximum directional deformation. It is clear from the load-deformation graph (figure 2) that the force and deformation diagram matches very well to the Rikard (2000) model which proves that the quality of the FE results is good. Therefore, further modelling and analysis using FEM follows in the next sections of the paper.

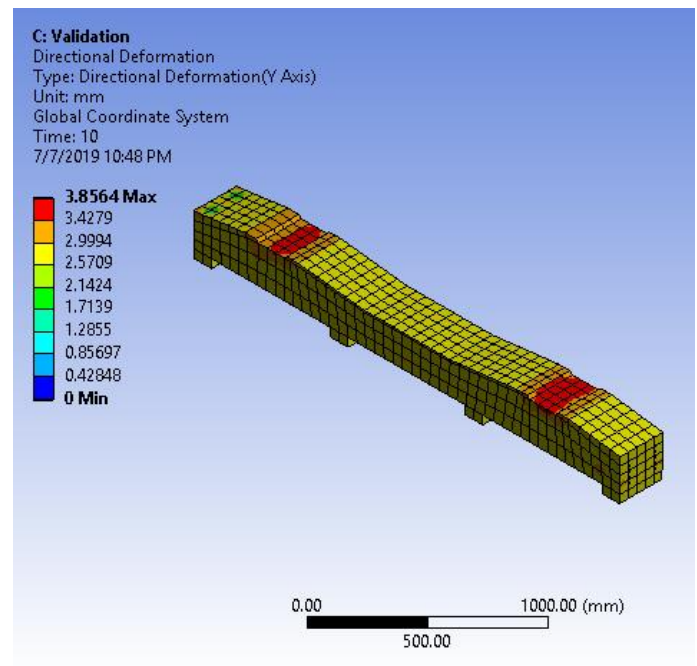

Figure 1. Deformation at 237.5 kN

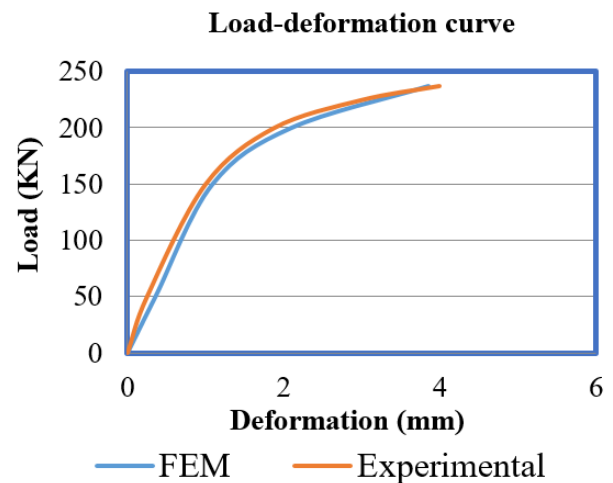

Figure 2. Force - Deformation graph

4. Numerical Model

4.1. Geometrical shape and dimensions of modelled sleeper

Different cross sections of sleeper at both rail seat and center were selected: trapezoidal, rectangular, and irregular hexagon cross section, taking into account the variation in sleeper size. The sleeper is symmetric in shape and size about its centre portion. The selections of sleeper dimensions were first based on the minimum values of bottom and top width at both rail seat and center section and minimum height. Using the equation proposed by Australian Standard (2003) [10], the rail seat load was computed as 159.375 KN based on the axle load of 25 tones, distribution factor of 0.51 and impact factor value of 250% proposed by

[4,10]. Minimum bottom width, top width and height were limited to 255 mm, 168 mm and 160 mm respectively. Existing sleeper used by Ethiopian Railway Corporation (ERC) [12] was considered and its corresponding volume, surface was computed as 0.1139 m³ and 0.68 m² respectively. Sleeper having same volume, soffit area, heights, volume and soffit area, volume and heights, soffit area and heights as the existing sleeper were considered as constraints. The excel random between functions between the minimum and the maximum dimensions, was used to generate the random geometrical parameters. In addition to this, the moment of inertia at both sleeper rail seat section and center section was taken also as the basis of the sleeper selections. Therefore, fifteen models with their corresponding dimensions were selected.

4.2. Material properties

The concrete grade C60 and prestressing steel wire of 7 mm diameter was used in this paper. The maximum permissible stress in concrete after allowing all losses of prestress were proposed by [4,10] and in compression and in tension, the formula of $0.45 * f_c'$ and $0.4 * (f_c')^{0.5}$ was proposed respectively. The value of stress for stretching prestressed reinforcement in the steel wire of $0.75 * f_{plk}$ must be used as proposed by Chinese Standards [13]. Therefore, a use of characteristic strength and young modulus of steel wire of 1,570 Mpa and 200,000 Mpa was proposed. The initial strain of 0.00058875 m/m = 5.8875 mm/m was also computed. Table 1 shows in details the for concrete and prestressing wires properties.

Table 1 Material properties of concrete and prestressing steel [11,13,14]

S/N	Properties	Concrete	Prestressing wires
1	Density (ρ_c), kg/m ³	2400	7,800
2	Young's modulus, (E_c), Mpa	37,720	200,000
3	Poisson's ratio (μ_c)	0.2	0.3
4	Thermal expansion (α_c), /c	$1 * 10^{-5}$	-
5	Strain value	0.003	0.00542
6	Yield strength (Mpa)	55	1,750
7	Tensile strength (Mpa)	2.85	1,085
8	Shear transfer	0.9	-
9	Characteristic strength (Mpa)	60	1,570

4.3. Prestressed concrete sleeper modelling

4.3.1. Static analysis in ANSYS

Sleeper modelling was conducted with ANSYS 16.0. For analysis purposes, since the sleeper was symmetric, a half sleeper was considered. Hex dominant meshing method was used for all models with mesh size of 25 mm for all models (figure 3). The support of the sleeper is modelled as a spring, as per (Shan, 2012) and [15]. For all cases, the ballast stiffness was

computed considering two layers; ballast and sub-ballast. As per [16]; the distribution angles for both ballast and sub-ballast are assumed to be 30 degrees and 35 degrees respectively for the two layers with 300 mm and 200 mm thickness respectively. The corresponding elastic moduli for the two thicknesses are 200 Mpa and 150 Mpa respectively, [17,18]. A set of solutions are available in ANSYS such as deformation (total or directional) and stresses (equivalent, and shear). The relationship between the three stresses was reported by [19] when the normal stress in times of bending stress was converted into an equivalent stress.

With σ_v = Equivalent (Von-Mises) stress, σ_b = bending stress and σ_s = shear stress, then

$$\sigma_b = \sqrt{(\sigma_v)^2 - 3 * (\sigma_s)^2} \quad (2)$$

4.3.2. Explicit dynamics in ANSYS

Explicit dynamic in ANSYS Workbench was used to model impact loadings so as to analyze impact analysis of prestressed concrete sleeper (figure 4). The model is hammered by the impactor that generates an impact force when it is given an initial velocity. The velocity given to the impactor and its contact to the element to analyze, creates an impact force.

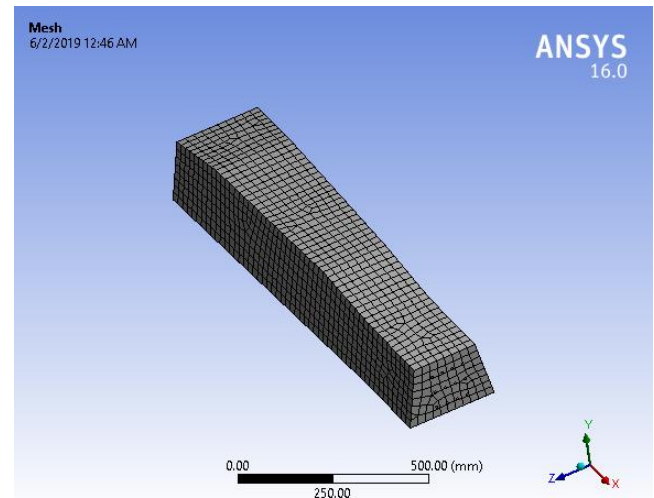

Figure 3. Hex dominant mesh method

The mass of the impactor is taken as the mass of the wheel as reported by [4&15]. It was assumed that the rail and the impactor are made of steel that bear similar properties according to [4]. The same meshing method and element size used in static structural analysis was maintained for explicit dynamics analysis. In this paper, the same properties used for static structural analysis are assumed to be same for explicit dynamic analysis corresponding to both concrete and prestressing wires. The drop velocity was 1.373 m/s equivalent to 0.1m drop height. The initial velocity on the impactor was set so that the impact event on the sleeper is created. The ballast stiffness used to support the sleeper is not supported by explicit dynamics, hence, the fixed support was assumed for all models which don't affect the stress result.

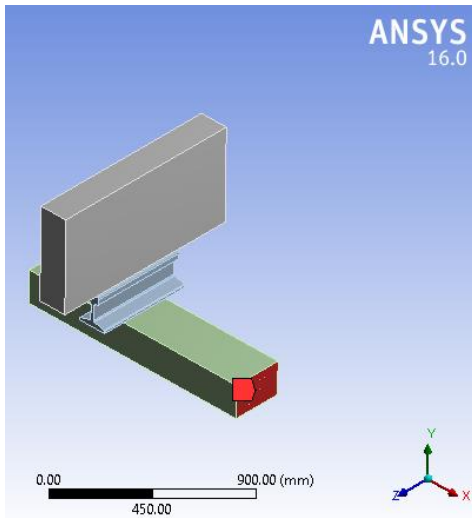

Figure 4. Model geometry

5. Results and Discussions

In this section, the analysis results of all models are presented to obtain the deformation and stresses for different sleepers. Stresses and deformations at rail seat were considered, results at center and end section were not considered in the analysis as they were too small.

5.1. Static results

In ANSYS 16, static structural analysis determines the displacements, stresses, strains, and forces in structures or components caused by loads. Critical sections such as the rail seat, center and end sections were emphasized and maximum deformation and stresses in concrete are located at rail seat section. The higher total deformation and stresses are located at rail seat section and at end and center sections are too small compared to the rail seat results. The equivalent stresses and shear stresses were recorded from ANSYS 16.0 and the corresponding bending stresses were computed based on equation 2. Both total deformation and stresses are shown in figure 5, 6 and 7. The lower deformation is located in rectangular section sleeper (SL-2) and (SL-5), whereas the higher pick values at sleeper, (SL-7). As shown in Figure 6 and 7; the higher bending stress at top sleeper section were located in sleeper (SL-4) followed by sleeper (SL-10) while the lower value to sleeper to sleeper (SL-1) followed by sleeper (SL-8) and ((SL-13). The higher bending stress at bottom rail seat section was located to sleeper (SL-5) followed by sleeper (SL-10) and the lower value at sleeper (SL-7). The results in Figure 6 and 7 shows that all modelled sleeper resist the static loadings imposed on them. Therefore, all selected sleepers are safe.

5.2. Impact results

The impact simulations were conducted on fifteen models. The total deformation and bending stress are also shown in figure 5, 6 and 7. The lower pick deformation is located in rectangular section sleeper (SL-2) and (SL-5), whereas the higher pick at trapezoid sleeper section, (SL-6) and irregular hexagon sleeper section, (SL-8). The equation 2 has been used to compute the

bending stress. The higher bending stresses at top sleeper section were located in sleeper (SL-8) while the lower value to sleeper (SL-2) and (SL-5). The higher bending stress at bottom rail seat section was located to sleeper (SL-5), (SL-2) while the lower values to sleeper (SL-9) and (SL-13). The sleeper: (SL-7), (SL-8), (SL-9), (SL-11) and (SL-13) was found to be safe. The similarities from SL-1 to SL-6 found in figure 5 for deformation of those sleepers subjected to both static and impact loadings is due to the similar shape of the sleeper base.

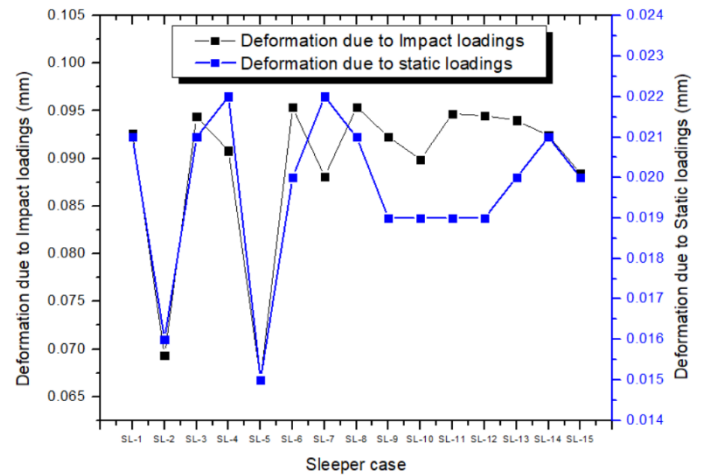

Figure 0. Deformation due to both static and impact loadings

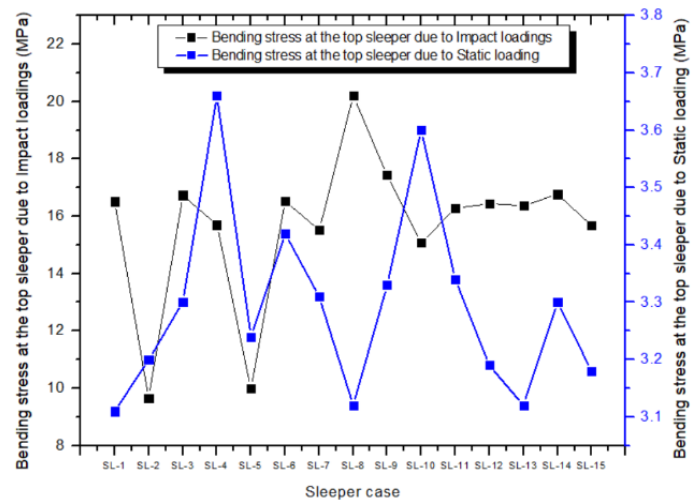

Figure 6. Bending stress at top sleeper due to both static and impact loadings

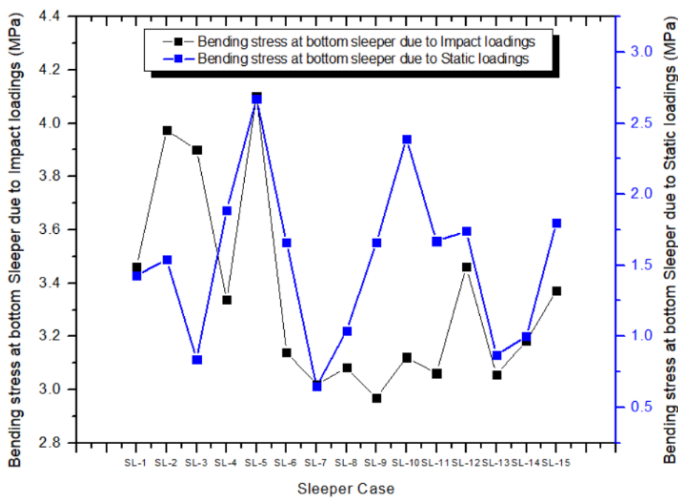

Figure 7. Bending stress at bottom sleeper due to both static and impact loadings

5.3. Selection of the best geometrical sleeper shape

5.3.1. Ranking the sleeper according to safety

Safety ranking was based on bending stress in comparison with the permissible stresses. The total deformation was not considered in the analysis as they are qualifying very small values as shown in figure 5. The bending stress has to be lower than the permissible stresses provided by Australian standard [10]. Therefore, the ratio between the permissible stresses and the

bending stresses should be greater than 1. The corresponding permissible stress in compression and tension are 27 Mpa and 3.1 Mpa respectively. Ratios for the selected five sleepers were computed for the sleepers as shown in table 3 with their corresponding safety ranking. To evaluate and rank the consideration of the criteria in these sleepers; a value of 1 to 5 was assigned to the selected sleeper. The two objective functions (compression and tension) contributing to the overall ranking, are having equal coefficient. Therefore, the overall ranking was computed with the summation of the two objective functions values. Rank one was given to the lower value as shown in table 2. The sleeper with lowest overall ranking was selected as the safest sleeper to resist impact loadings.

The static results were reviewed against safety for the sleeper shown in table 2 above. Respective individual ratios and ranking are shown in table 3. The overall safety ranking as far as static loadings are concerned, were computed in the similar procedures as for impact results. The overall safety ranking combining both static and impact results is shown in table 4. Investigations made on the sleeper able to resist the applied impact loadings showed that sleeper (SL-7) of irregular hexagon shape with a varying width was the safest compare to the other selected sleeper shapes. Sleeper (SL-13) was the safest when the static loadings were considered. The selected sleeper was of rectangular sections, trapezoid sections and irregular hexagon sections. Among those models; the irregular hexagon sections were the safest sleeper shape as far as the impact loading and static loading are concerned.

Table 2 Ratio of permissible and bending stress according to impact results and safety ranking

Sleeper Cases	Top Bending Stresses (Mpa)	Ratio	Ranking	Bottom Bending Stresses (Mpa)	Ratio	Ranking	Sum of rankings	Overall ranking
SL-7	15.52	1.74	1	3.02	1.026	2	3	1
SL-8	20.20	1.34	5	3.08	1.006	5	10	4
SL-9	17.43	1.55	4	2.97	1.044	1	5	2
SL-11	16.28	1.66	2	3.06	1.013	4	6	3
SL-13	16.38	1.65	3	3.056	1.014	3	6	3

Table 3 Ratio of permissible and bending stress according to static results and safety ranking

Sleeper Cases	Top Bending Stresses (Mpa)	Ratio	Ranking	Bottom Bending Stresses (Mpa)	Ratio	Ranking	Sum of rankings	Overall ranking
SL-7	3.306	8.166	3	0.647	4.795	1	4	2
SL-8	3.122	8.648	2	1.040	2.982	3	5	3
SL-9	3.333	8.100	4	1.660	1.868	4	8	4
SL-11	3.336	8.095	5	1.672	1.854	5	10	5
SL-13	3.117	8.663	1	0.872	3.553	2	3	1

Table 4 Safety ranking according to both static and impact results

S/N	Sleeper Cases	Safety ranking as per static results	Safety ranking as per impact results	Sum of rankings	Overall ranking
1	SL-7	2	1	3	1
2	SL-8	3	4	7	4
3	SL-9	4	2	6	3
4	SL-11	5	3	8	5
5	SL-13	1	3	4	2

5.3.2. The total volume of the selected sleeper

Total number of sleepers modelled for static and impact simulations are fifteen. As far as impact results are concerned, five sleepers were selected to be safe. The corresponding total volumes and ranking were shown in table 5. It shows that the lower the volume, the lower the ranking number

Table 5 Total volume of the selected sleepers and their ranking

S/N	Sleeper Cases	Volume (m ³)	Ranking
1	SL-7	0.11419	4
2	SL-8	0.11421	5
3	SL-9	0.11215	2
4	SL-11	0.11366	3
5	SL-13	0.11211	1

The overall sleeper safety and volume ranking was computed according to equation 1. The objective functions are shown in table 4 and 5, the weighting coefficients are given as 0.59 (59%) and 0.41 (41%) for sleeper safety and sleeper volume respectively. As shown in table 6, the sleeper having the lower sum of ratings was considered as the best geometrical sleeper shape. Therefore, Sleeper (SL-13) having a sum of ranking of 1.59 was recommended as the best geometrical sleeper shape (figure 8), which was characterized by a different width at both the center and rail seat sections. In comparison to the existing sleeper (in the Addis-Djibouti railway track) in Ethiopia; the best geometrical sleeper shape has a 1.75% volume reduction. Irregular hexagon forms a sleeper that is safe compared to sleepers of other shapes considered in this research.

Table 6 Best geometrical sleeper shape selection

S/N	Sleeper Case	Sum of rankings	Overall ranking
1	SL-7	2.23	2
2	SL-8	4.41	5
3	SL-9	2.59	3
4	SL-11	4.19	4
5	SL-13	1.59	1

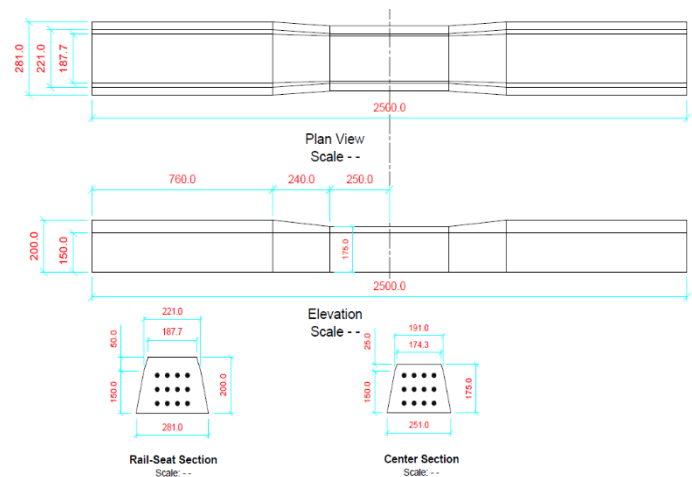

Figure 8. Best geometrical sleeper shape

6. Conclusion

Results from static simulation revealed that rectangular sleeper shapes are having the lower top stress and higher bottom stress compare to the other sleeper shapes. The trapezoid and irregular hexagon sleeper sections are having lower stress compare to rectangular sections. However, impact simulation's results proved that the irregular hexagon sleeper shapes resisted impact loadings much better compared to the other sleeper shapes. Optimization of sleeper was based on the criteria of sleeper safety, and sleeper total volume. Analysis results showed that the best geometrical sleeper shape was (SL-13) of an irregular hexagon with different widths at rail seat and center sections; 251 mm center width, 281 mm end and rail seat width, 175 mm height at center section and 200 mm height at end and rail seat sections. As per this research, the sum of rankings that included sleeper safety, cost in times of total volume for the best geometrical sleeper shape was 1.59. Sleeper (SL-7) was the next best geometrical sleeper shape with a similar ranking sum of 2.23. The shape of sleeper (SL-7) was an irregular hexagon with a varying width from center to end sections, having 248 mm as center width, 308 mm on the end section, 171 mm height at center section and 207.8 mm height at end and rail seat sections. This paper points out to irregular hexagonal shape sleepers to be economical and safe. Therefore, sleeper model (SL-13) that has an irregular hexagon shape is proposed for use on future extension of the existing lines and or in the construction of new lines. Future research in regards to concrete sleeper optimization are proposed to ensure the proper lateral stability; incorporating other track components such as rail, rail pad, ballast and subgrade as part of railway track system in order to better comprehend the effect of these components to the sleeper. To ensure both safety and fair sleeper manufacturing and material, sleeper cross-sectional and front view dimensions are recommended for further optimizations. Laboratory investigations are also recommended to be conducted in future.

Conflict of Interest Statement

The authors declare that there is no conflict of interest.

CRedit Author Statement

Ndabamenye Theogene: Writing original draft and revision, **Ntakiyemungu Mathieu:** article editing and revision, **Gebre Abraham:** Supervision, article editing and revision.

References

- Li, D., Kaewunruen, S., & Robery, P. (2017). Creep and shrinkage effects on Railway Prestressed concrete sleepers. First international conference on rail transportation-ICRT 2017, (pp. 1-8). Chengdu, China.
- Kaewunruen S. & Remennikov A. (2007). Experimental and Numerical Studies of Railway Prestressed Concrete Sleepers Under Static and Impact Loads. *Civil Computing*, 3, 25-28.
- Kaewunruen, S., & Remennikov, A. (2013). On the residual energy toughness of prestressed concrete sleepers In railway track structures subjected to repeated impact loads. *Electron. J. Struct. Eng.*, 41-61. engineering, Chalmers University of Technology.
- S. Kaewunruen. (2007). Experimental and numerical studies for evaluating dynamic behaviour of prestressed concrete sleepers subject to severe impact loading.. PhD thesis, UoW, Aust.,.
- Desalew, F. (2014). Analysis and Design of Prestressed Concrete Sleeper. Addis Ababa , Ethiopia.: Master's Thesis in Civil Engineering in the Graduate Studies, Addis Ababa Institute of Technology, Addis Ababa University, Addis Ababa , Ethiopia.
- Sadeghi, J., & Babae, A. (2006). Structural Optimization of B70 railway prestressed concrete sleepers. *Iranian Journal of Science & Technology*, Vol.30.,No.B4 School of Railway Engineering, Iran University of Science and Technology, Tehran, LR of Iran.
- Minoura, S., Wantanabe, T., Sogabe, M., & Gato, K. (2017). Analytical Study on Loading Capacity of Prestressed Concrete Sleeper. *Procedia Engineering*.
- Yang, X.-S. (2010). *Engineering optimization, an introduction with Metaheuristic applications*, . United Kingdom: University of Cambridge, Department of engineering, Cambridge, A JOHN WILEY & SONS, INC., PUBLICATION
- Johan, B. (2002). Railway Safety-Risk and economics,. PhD's thesis, Department of infrastructure and planning, Royal Institute of Technology, ISSN 1651-0216.
- AS. (2003). Australian Standard, AS 1085.14 "Railway track materials", Part 14: "Prestressed Concrete Sleepers".
- Rikard G. (2000). Static and dynamic finite element analysis of concrete sleepers. Göteborg, Sweden: Department of structural
- Corporation, E. R. (2012.). Ethiopia/Sebete-Djibouti/Nagad Railway Feasibility Study-Part 1: General Specifications Executive Edition,.
- Chinese, S. (2002). National Standard of People's Republic of China: Code of Design of Concrete Structures. GB50010-2002.
- Shan, L. (2012). Railway Sleeper Modelling with Deterministic and Non-deterministic Support Conditions. Master Degree Project.
- Hong Lim, C., Kaewunruen, S., & Mlilo, N. (2017). Performance of Railway Sleepers with Holes under Impact Loading. *IOP Conference Series: Materials Science and Engineering* 280., pp 1-6.
- Ahlebeck, D., Meacham, H., & Prause, R. (1975). The development of Analytical models fro railroad track. *Proc., Symposium on Railroad Track Mechanics (A. D. Kerr, ed.)*, (pp. pp. 239-261).
- Jabbar Ali, Z., & Seyed Ali, M. (2016). Study of ballast layer stiffness in railway tracks. pp. 311-318.
- Bowles, J. (1988). *Foundation Analysis and Design*. . New York.: Fourth edition, McGraw-Hill Book Company, .
- Ivanov, I., & Corves, B. (2014). Fatigue testing of flexure hinges for the purpose of the development of high-precision micro manipulator. "Mechanical Sciences; department of mechanism theory and dynamics of machines (IGM), RWTH Aachen University, Aachen, Germany, pp.59-66.